

TG1 - Scala Dynamic Cone Penetrometer - Cone Calibration

TG Number:	TG1	Author:	Steven Anderson
Revision number:	0	Issue Date:	September 2011

1 INTRODUCTION

The scala dynamic cone penetrometer is frequently used by laboratories in measuring the strength of soils in-situ. The calibration of the scala penetrometer is detailed in NZS4402:1988 Supplement Test 6.5.2. The key measurements for the calibration are: the hammer mass, the drop height, the length of the graduated rod, the graduation intervals and the dimensions of the cone. Of all the components, the cone is subject to the most wear and yet it's only essential dimension is the diameter. It is important that the surface area of the cone does not wear too much to influence the results. This guideline is a best practice guide of acceptable wear limits to assist in the calibration of a scala penetrometer cone.

2 CALIBRATION REQUIREMENTS FOR THE CONE DETAILED IN NZS4402: 1988 SUPPLEMENT TEST 6.5.2

The drawing of the cone in NZS4402, details the angles of the cone tip, the length of 60° cone and the diameter of the cylindrical section. One dimension is missing, the length of the cylindrical section.

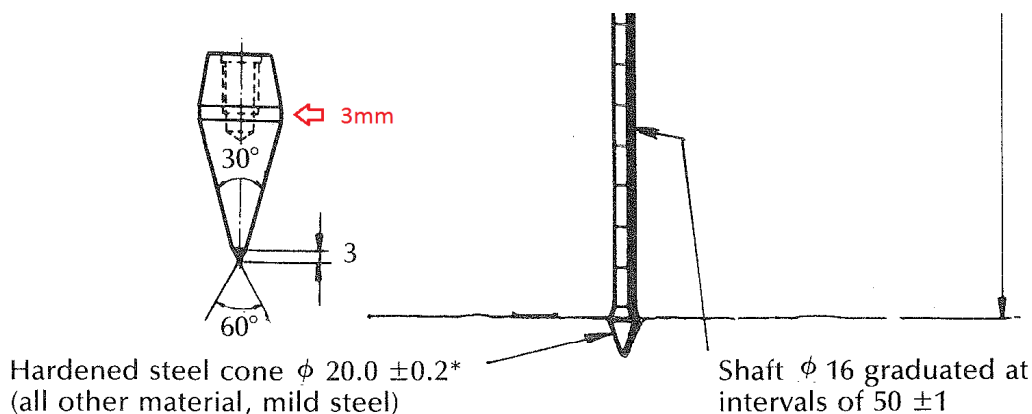

NOTE –

- (1) All linear dimensions are in millimetres (not to scale).
- (2) Essential dimensions are indicated by an asterisk.
- (3) This design has been found satisfactory but alternative designs may be employed provided the essential requirements are fulfilled.
- (4) Similar equipment has sometimes been referred to in New Zealand as the Scala Penetrometer.

Fig. 6.5.2
DYNAMIC CONE PENETROMETER

TG1 - Scala Dynamic Cone Penetrometer - Cone Calibration

TG Number:	TG1	Author:	Steven Anderson
Revision number:	0	Issue Date:	September 2011

3 RECOMMENDED CALIBRATION MEASUREMENTS AND TOLERANCES

The test method omits some important calibration measurement information:

- a) Tolerance on the angles of the cone and the tip.
- b) The length of the cylindrical section.
- c) Acceptable wear.
 - i) Wear of the cone angles
 - ii) Wear of the overall length

3.1 Tolerance on the angles of the cone and the tip

Immediately after a scala cone is first used, the 60° cone is rounded, therefore this dimension is only a manufacturing dimension which is only required for the initial calibration. The 30° cone is the important angle. The suggested tolerance for the angle measurements are ±1°.

3.2 The length of the cylindrical section

If the above drawing (fig 6.5.2) is to scale, the length of the cylindrical section can be visually assessed to be around 3mm. A survey of New Zealand manufacturers indicated the length was in a range of 10mm to 13mm whereas Australian manufacturers reported a range of 3mm to 5mm. Scala, the inventor of the Scala Dynamic Cone Penetrometer was based in Melbourne when he developed the equipment. In Melbourne the local suppliers manufacture cones with a 3mm long cylindrical section. Therefore the length of the cylindrical section should be 3mm. This measurement is only required as an initial calibration because the shoulders of the cylinder wear rapidly.

3.3 Acceptable wear

3.3.1 Wear of the cone angles

As mentioned in 3.1, the 60° angle is immeasurable after the first use. The important angle is the 30° cone, which is the bearing area of the test. An independent calibration assessment of the 30° angle on a worn cone indicated the wear to be uniform and the angle was still 30°. The 30° angle can be used as a calibration measurement with a tolerance of ±1°.

TG1 - Scala Dynamic Cone Penetrometer - Cone Calibration

TG Number:	TG1	Author:	Steven Anderson
Revision number:	0	Issue Date:	September 2011

3.3.2 Wear of the overall length

The reduction in length over time is a good indicator of wear. To determine what an acceptable wear length should be, we start with a calculation of the length of the conical sections of the cone which are calculated to be 33.857mm. We can compare this to a calculation of length if the diameter of the cylindrical section wears to 19.8mm (the lowest allowable wear diameter) and the cones wear evenly, but without wear rounding of the tip, this gives us a length of 33.684mm. Further, if we allow for spherical rounding of the tip plus the cylindrical wearing, then the worn length is 32.489mm. This equates to a 1.368mm loss in length from the original length of 33.857mm. The CETANZ Committee decided that a 3mm loss in length is acceptable. In order to measure the wear effect on length, the overall length when purchased can be recorded, and subsequent calibration compared against the original measurement.

3.3.3 Wear of the cylindrical diameter

The cylindrical diameter has an essential dimension of 20mm \pm 0.2mm. With the length of the cylinder being manufactured to 3mm instead of the current 10mm to 13mm, it is likely that the diameter will become the wear measurement that fails calibration ahead of angle and length.

4 SUGGESTED CALIBRATION JIG PLATE

It is suggested that suppliers, manufacturers or laboratories manufacture a simple calibration jig plate to check for wear of a scala cone. The jig could have a:

- a. 29° and 31° angle to check the 30° cone.
- b. 19.8mm hole to check the cylindrical section is not too worn.
- c. Minimum cone length gauge specific to the manufacturer/supplier.

5 DISCLAIMER

The information in this publication is to encourage high standards within the civil engineering testing industry. The information is intended as a technical guide for CETANZ members only and in no way replaces New Zealand standards or requirements of project specifications. CETANZ cannot accept any liability of any sort for unsatisfactory site or laboratory work carried out by Companies who are members of CETANZ or organisations who claim to be following these guidelines. CETANZ assumes no responsibility for any loss which may arise from reliance on the guideline and disclaims all liability accordingly. Specialist and/or legal advice should always be sought on any specific problem or matter.

TG1 - Scala Dynamic Cone Penetrometer - Cone Calibration

TG Number:	TG1	Author:	Steven Anderson
Revision number:	0	Issue Date:	September 2011

REFERENCES

- AS 1289.6.3.2: 1997 *Methods of testing soils for engineering purposes – Soil strength and consolidation tests – Determination of the penetration resistance of a soil – 9kg dynamic cone penetrometer test*, Australian Standards.
- ASTM D6951-03 *Standard test method for use of the dynamic cone penetrometer in shallow pavement applications*, ASTM International.
- NZS 4402: 1986 Test 6.5.2 *Determination of the penetration resistance of a soil – Hand method using a dynamic cone penetrometers*, Standards Association of New Zealand, Supplementary Tests (November 1988).
- Scala, A.J, 1956. *Simple Methods of Flexible Pavement Design Using Cone Penetrometers*. Proceedings of the Second Australia-New Zealand Soil Mechanics Conference, Christchurch, New Zealand. Pp.73-84

m:\500\technical\cetanz\technical wg\cetanz guidelines\tg_ cetanz technical guideline template.doc